



STANDARD EQUIPMENT	OPTIONS
Proportional controls with wired remote	2'6" wide aluminum basket
Tracks driven by variable displacement motors and braking system	5'9" wide aluminum basket
Tracks can be widened by 15" to increase stability while traveling	7" display at the ground control station
95 Ah AGM Starting Battery	Wireless radio remote control with battery charger in basket and back-up wire
11.5 US gal oil tank	420° rotation (+/- 210°)
Easy access throughout the unit with quick remove doors and covers	10 HP Diesel Hatz Engine w/ 1.4 US gal tank
Automatic stabilization and slope sensor	All Electric LiPo power option <i>Zero Emission</i>
Emergency lowering valves and hand pump	Non-marking tracks
4'6" wide aluminum basket with integrated ladder	Junction debris protection kit
110V socket in the basket	12V Emergency electric pump
USB plug in the basket	Single phase 110V/12A motor with plug for all-electric operation
High durability tracks	Air&water line in basket
4" Display on the ground control station	Auto stowing function
All wiring inside to boom to protect from damage	Toolbox
Jib stow function to increase departure angle	12Vdc light in basket
Electronic speed control	Custom colors
3 travel speeds	Customized labels
Engine start/stop switch on the ground control station	Outrigger pads
Manual controls on the ground control station	Two security harnesses kit
Bypass key to override the safety features in case of emergency	Basket proximity sensor kit
Quick remove basket with built-in caster wheels	Extended warranty programs
Master/Slave hydraulic basket leveling	Activation of only one chosen work area with consequent block of the other areas
Engine Start/Stop from the Ground Control or the Remote	
Holding valves on all cylinders	
Pressure relief valves	
Hour meter	
2 year machine warranty with 5 year structural warranty	



AGENCY_ASUAR.IT

AL68

North American Distributor:



9725 Industrial Drive
Bridgeview, IL 60455

www.craneandmachinery.com



Work area

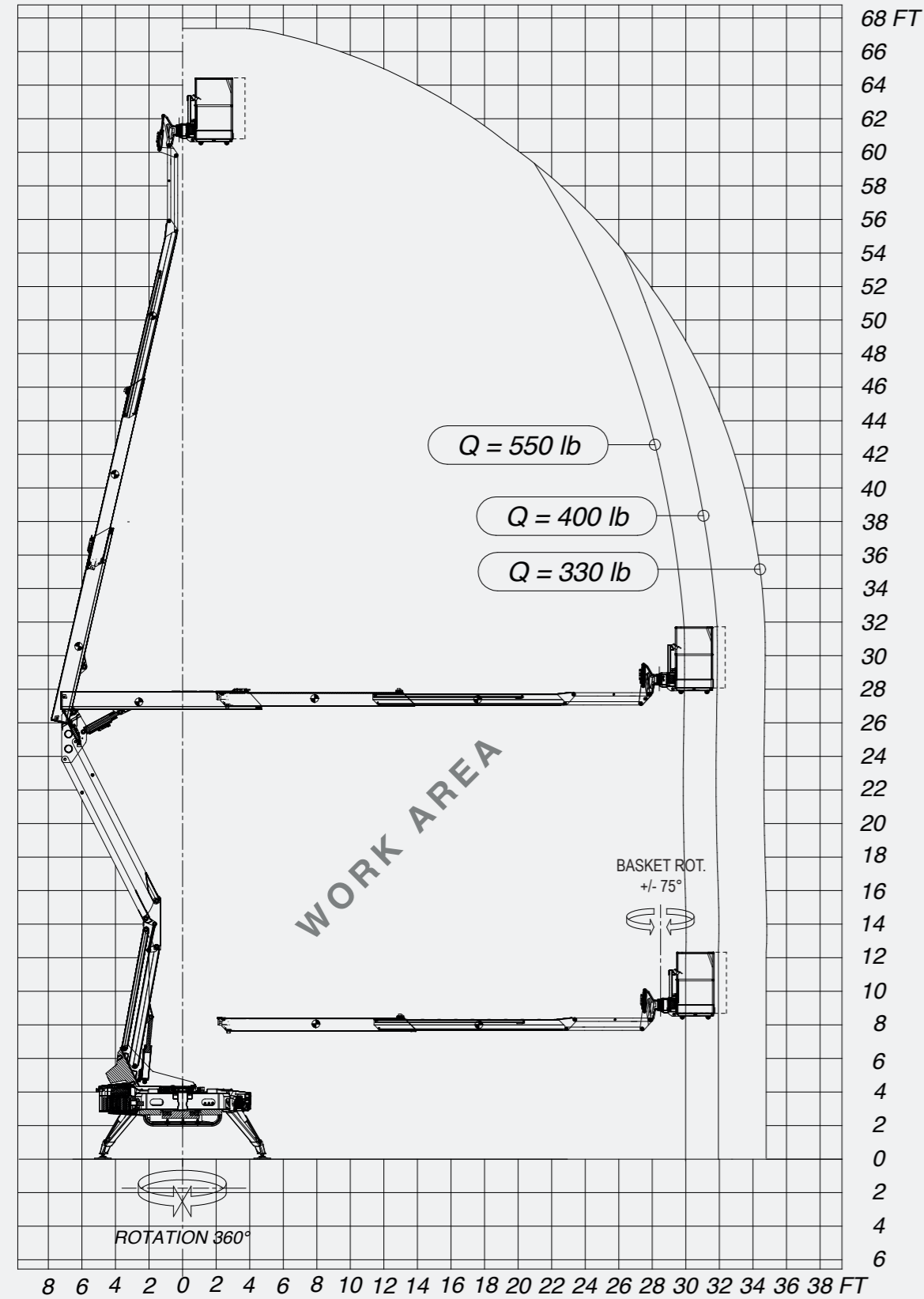

Technical drawings

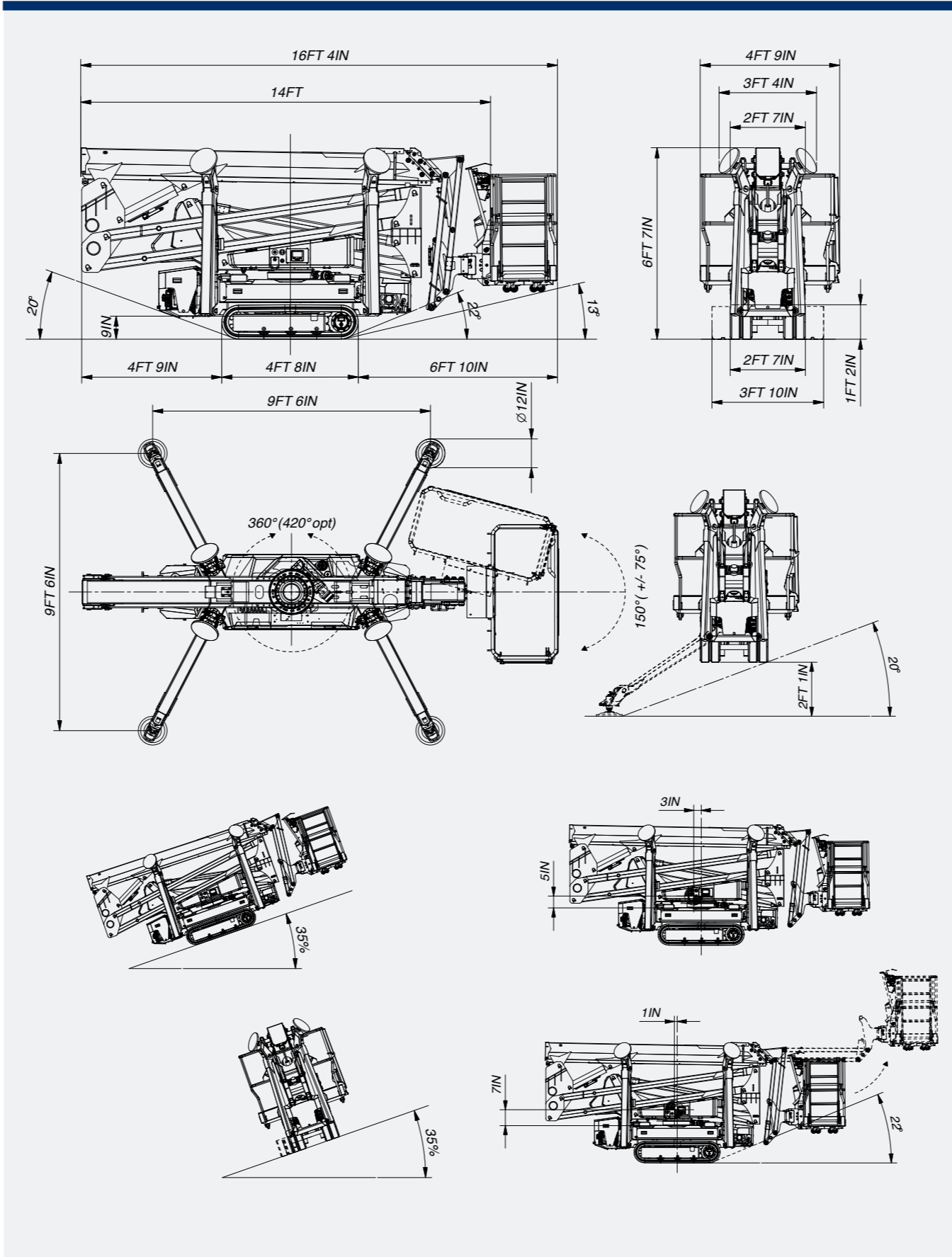

Technical features

Max working height	67' 11"	Basket height	3' 7"
Max platform height	61' 4"	Basket length	4' 7"
Max horizontal working outreach	34' 9"	Basket width	2' 4"
Up and over height	26' 11"	Transport length	16' 5"
Max load capacity	550 lbs	Transport length without basket	14' 1"
Aerial part controls	Wired control or Radio remote control	Transport height	6' 6"
Outriggers - Crawler controls	Wired control or Radio remote control	Min transport width	2' 7"
Basket material	Aluminum	Ground clearance	10"
Jib articulation	0-116°	Track footprint	4' 8" x 10"
Jib - degree of rotation	NA	Open outriggers footprint	9' 6" x 9' 6"
Basket - degree of rotation	+/- 75°	Semi-open outriggers footprint	NA
Column - degree of rotation	+/- 180°	Closed outriggers footprint	NA
Max ground slope working angle	18°	Outrigger plate diameter	1'
Stabilization height	2' 1"	Weight of the standard unit	5952 lb
Tracks width (Closed-Open)	2' 7" - 3' 10"	Max ground pressure on tracks	11,4 psi
Max slope allowed in travel mode	35%	Max ground pressure on stabilizers	48,4 psi
Max travel speed	1,6 mph	Max reaction of stabilizers	5291 lbf
Variable outriggers footprint	NA	Combustion engine STD	Gasoline Honda Igx390 11.7HP
Auto stowing function	Optional	Fuel tank	1,6 gal
Automatic stabilization	✓	110V Standard Electric Motor	110V/12A
Jib stow function to increase departure angle	✓	Diesel engine option	Diesel Hatz 1B50E 10 HP
Emergency lowering system	✓	LiPo battery pack option*	73.6 V - 7.4 kWh - 4kW engine

*Combustion engine is excluded